

A NOVEL WIDEBAND MICROSTRIP PATCH ANTENNA FOR SATELLITE COMMUNICATIONS IN KU-BAND

Gulzar Ahmad^{1*}, M. Inayatullah Babar¹, M.Irfan¹

ABSTRACT

In this paper bandwidth enhanced microstrip patch antenna has been proposed for satellite communications. The bandwidth has been increased using parasitic patches. The size of the proposed antenna is 15x8mm². It has been observed that the antenna has a bandwidth of 4.08GHz, a return loss of 49.07dB at the center frequency, a maximum gain of 8.25dBi and total efficiency of more than 90%. This antenna can be prospective candidate for satellite communications.

Index Terms: Return Loss, Bandwidth, Gain, VSWR and Ku-Band

INTRODUCTION

Microstrip patch antenna is used widely due to low profile, compact size and easy fabrication, therefore the implementation of VSAT system with low profile antennas has been under consideration by researchers since last decade. Bryon, in 1970's, designed the microstrip radiator which consisted of a several wavelengths long and half-wavelength wide conducting strip (E.V. Bryon, 1970). The ground plane was separated by a dielectric strip and it is fed using coaxial connectors at regular intervals. After that, Howell, in 1975, presented a radiator by using basic circular and rectangular shapes (J.Q. Howell, 1975). The designed antenna was low profile consisted of planar radiating element whose substrate thickness was very low as compared to the wavelength. From the study, author noted that the antenna bandwidth depends on the thickness and relative permittivity of substrate. With the development, number of geometries of microstrip patch antennas was presented for space applications. The cylindrical array was constructed for S-band applications (H.D. Weinschel, 1973); conformal array was designed for KC-135 aircraft for L-band communication (G.G. Sanford, 1974). Some flush mounted antenna arrays were also presented for missile systems (J.R. James & G.J Wilson, 1975), (G.W. Gravin et al., 1975)

A microstrip patch antenna is a type of radio antenna which consists of dielectric substrate, ground and radiating patch. The top of the substrate consists of a metallic strip (patch) and the bottom of substrate consists of the ground plane. The feed line is connected to the lower end

of the monopole and ground plane. The most common shapes of microstrip patch antennas are rectangular, circular, square, triangular and elliptical (C.A. Balanis, 2005); but the combination of these shapes can also be used for the design of microstrip patch antennas. VSAT system is used for satellite communication and Ku band (12-18 GHz) is widely used band in such system (Jana et al., 2013), (Krishna et al., 2008).

Recently various microstrip patch antenna for Ku band application are reported. Azim et al. presented the patch antenna for Ku band application with bandwidth of 0.95 GHz, peak gain of 7.6 dB and size of 15 x 15 mm² (Azim et al., 2011). (Dubey et al., 2011) proposed antenna with rectangular shape, the bandwidth of proposed antenna was 0.6 GHz, 0.52 GHz and 0.382 GHz for various bands and antenna size was 7.6 x 10 mm² which was printed on Teflon with thickness of 0.8. (Misran et al., 2009) developed Ku band microstrip antenna with size of 9.5x10mm² which was printed on Rogers RT/Duroid 5880. The thickness of the substrate was 0.254mm and maximum bandwidth was 0.90 GHz. (Samsuzzaman et al., 2013) designed Ku band antenna on Rogers RT/Duroid 6010. The size of the antenna was 8.5 x 7.96mm² and height of substrate was 1.905mm. The bandwidth was 0.576 GHz. Islam et al., (2010) presented Ku band antenna with size of 9.50 x 10 mm² and height of substrate was 0.254 mm. The return loss was 23.83dB and 14.04dB at various bands. (Malisuwan et al., 2014) developed E shaped antenna for Ku band application with size of 22.75 x 16.5mm². The design was printed on FR4 with thickness of 1.5mm. (Chodavadiya et al., 2016) presented Ku band microstrip patch antenna which was

1 Department of Electrical Engineering, UET, Peshawar, Pakistan*

designed on Teflon with thickness of 0.8 mm. The size of the antenna was 4.5 x 23.2 mm². The peak gain was 6.906dB, bandwidth was 4.1553 GHz and return loss was 26.5578dB. In (Nor et al., 2016) an antenna has been reported with 2.1GHz impedance bandwidth and gain of the antenna was 12.1dB.

The maximum simulated bandwidth was 13.3% at 12.57GHz resonant frequency in (Elias, 2016). The VSWR was < 2 in the case of using infinite ground plane.

In this paper a Microstrip Patch Antenna has been designed for satellite applications in Ku-band. The size of the antenna is 15x8 mm². The bandwidth of the antenna is 4.08GHz, a return loss of 49.07dB, a maximum gain of 8.25dBi and total efficiency of more than 90%. The antenna has been simulated using CST Microwave Studio.

ANTENNA DESIGN METHODOLOGY

The dimensions (i.e. length and width) of the proposed antenna were calculated according to the following equations. where, L is the length of patch, c and v_0 represent the speed of light, f_r is the resonant frequency, ϵ_{eff} is the effective dielectric constant calculated using Eq. (2), ΔL represents the extension in length caused by the fringing effect and by considering the dimension of the patch it can comfortably be ignored, ϵ_r is the relative permittivity of substrate, h is the thickness of substrate and W is the width of patch, respectively.

$$L = \frac{c}{2f_r \sqrt{\epsilon_{eff}}} - 2\Delta L \tag{1}$$

$$\epsilon_{eff} = \frac{\epsilon_r + 1}{2} + \frac{\epsilon_r - 1}{2} \left[1 + 12 \frac{h}{w} \right]^{-1} \tag{2}$$

$$\frac{\Delta L}{h} = 0.421 \frac{(\epsilon_{eff} + 0.3) \left(\frac{w}{h} + 0.264 \right)}{(\epsilon_{eff} - 0.258) \left(\frac{w}{h} + 0.8 \right)} \tag{3}$$

$$W = \frac{V_0}{2f_r} \sqrt{\frac{2}{\epsilon_r + 1}} \tag{4}$$

Initially a simple rectangular antenna was designed as shown in Fig.1. The patch has been etched on the substrate Preperm L-450 and it has a dielectric constant of 4.4 and height of 1.64 mm. The antenna substrate has a size of 12x8 mm². The ground plane and the simple rectangular patch have been made of pure copper with 0.035 mm thickness. The coaxial feed line is located on

the x-axis at 1.125mm. The simple copper rectangular patch has a size of 4.5x2.5 mm². This simple antenna showed a bandwidth of 1.56 GHz from 13.64 GHz to 15.2 GHz and a maximum return loss of 26.15 dB as shown in Fig.2.

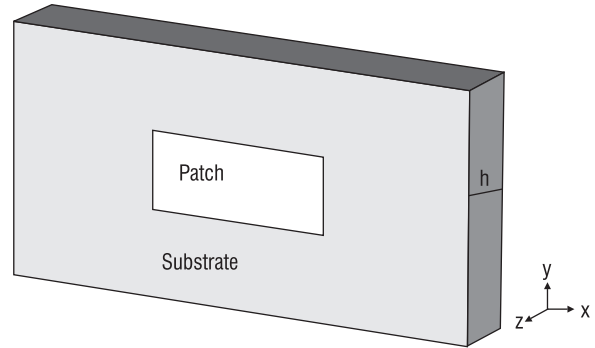

(a)

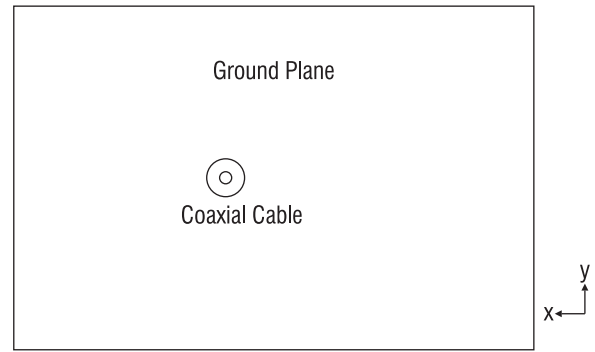

(b)

Fig 1: The Simple rectangular antenna (a) Perspective View (b) Back View

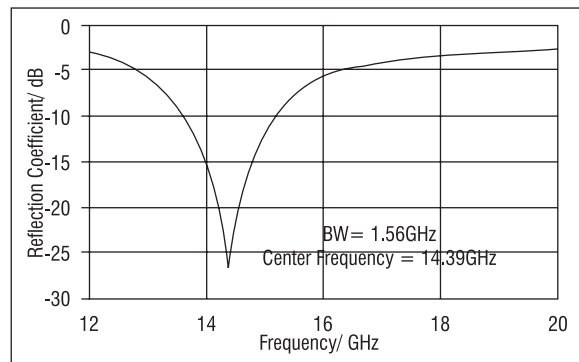

Fig 2: Return loss of Reference patch antenna

For bandwidth enhancement, this Ku-band antenna was modified in shape along with addition of parasitic patches as shown in Fig 3. The two parasitic patches P_1 and P_3 are introduced on the left and right side of

the central radiating (driven) patch P_2 respectively. Four identical rectangular slots have been removed from the driven patch P_2 and these rectangular slots are represented by S. The gap between the parasitic patch P_1 and the driven patch P_2 is denoted by G_1 and the gap between the driven patch P_2 and the parasitic patch P_3 is denoted by G_2 .

The driven patch is excited by a 50Ω coaxial cable. The parameters of the proposed antenna are given in Table 1. The area of the patches is $W \times L \text{ mm}^2$. Where, W and L stand for width and length respectively The substrate's material was Preperm L-450 having a dielectric constant of 4.4.

Table 1. Parameters of the Proposed Antenna

Name	Description of the Parameters	Values
A	Size of the rectangular antenna	$15 \times 8 \text{ mm}^2$
A_1	Size of the driven patch P_2 without rectangular cuts	$5 \times 2.6 \text{ mm}^2$
A_2	Size of the left and right parasitic patches P_1 and P_3	$3 \times 2.6 \text{ mm}^2$
C	Location of coaxial feed line on the x axis	1.2 mm
G_1	The gap between the parasitic patch P_3 and the driven patch P_2	1.3 mm
G_2	The gap between the parasitic patch P_1 and the driven patch P_2	1 mm
S	Size of the four rectangular cuts from the corners of the driven patch P_2	$1.75 \times 0.7 \text{ mm}^2$
T	Thickness of the ground plane and all the three patches	0.035 mm
H	Height of the substrate	1.64 mm

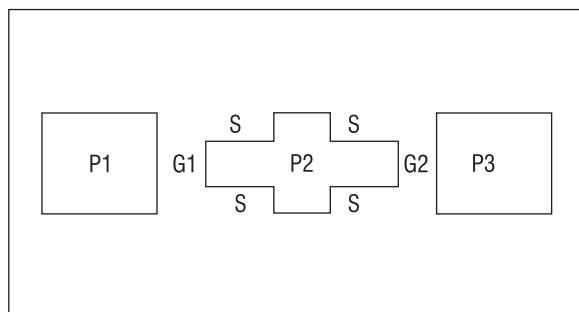

Fig 3: Front View of the Proposed Antenna

RESULTS AND DISCUSSION

A Reflection coefficient

The reflection coefficient as a function of frequency is illustrated in Fig.4. The centre frequency is close to 15GHz and the bandwidth of the proposed antenna is 3.87GHz with maximum Return loss of 38.64dB.

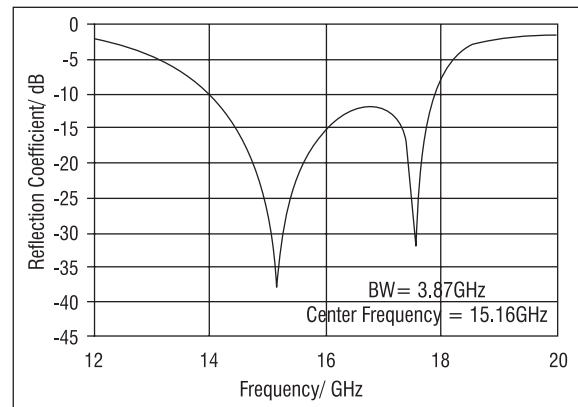

Fig 4: Return Loss of the proposed antenna

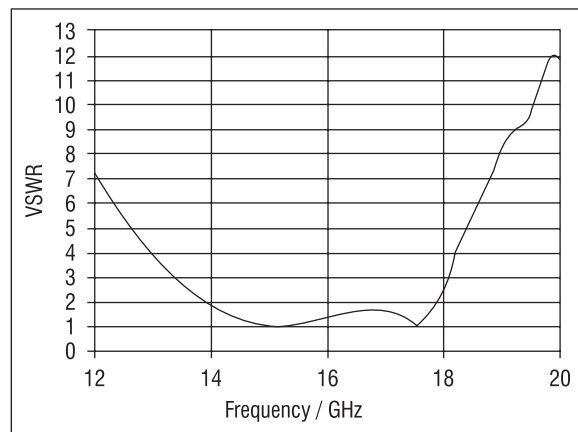

Fig 5: Voltage Standing Wave Ratio

B Voltage Standing Wave Ratio

The Voltage Standing Wave Ratio of the proposed antenna is shown in Fig. 5. The ratio is in the desirable slot between 1 and 2.

C Efficiency

The efficiency is shown in Fig.6. The total efficiency is more than 90% in the entire working spectrum. The maximum radiation efficiency is approximately 98 %.

D Radiation Pattern

The two dimensional radiation pattern of the antenna are shown in Fig. 7. The antenna has broadside radiation pattern with small back lobe.

The half power beamwidth of 111.7° , 107.2° , 101.2° and 93.2° have been achieved at 14.66 GHz, 15.55GHz, 16.44 GHz and 17.33 GHz respectively.

The variable gain from 6.23dBi to 8.48dBi is attained by the antenna. This antenna has achieved the maximum gain of 8.48 dBi at 17.33 GHz frequency.

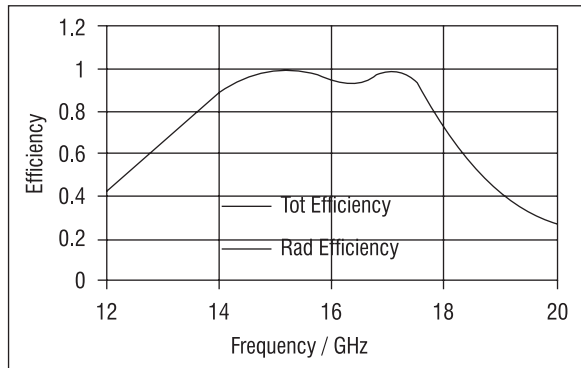
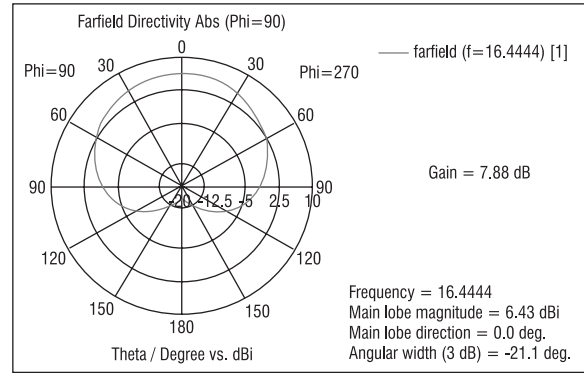
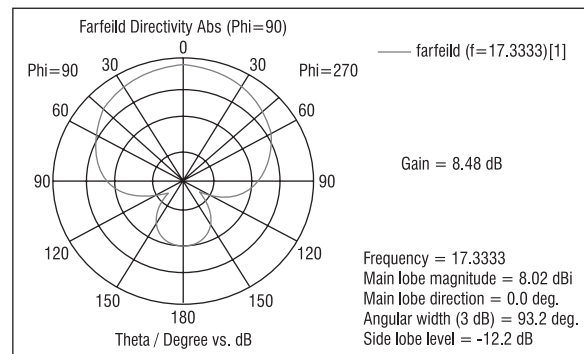

Fig 6: Efficiency of the proposed antenna



(c)



(d)

Fig 7: Two Dimensional Radiation Pattern at (a) 14.66 GHz (b) 15.55 GHz (c) 16.44 GHz (d) 17.33 GHz

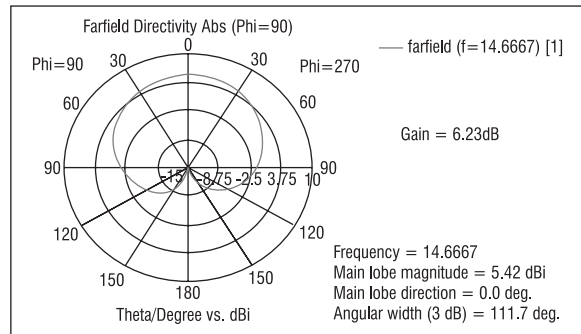

(a)

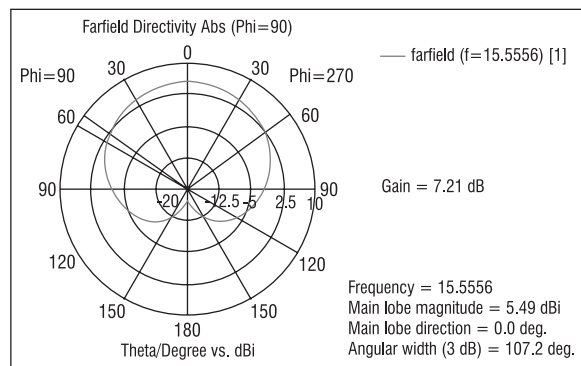

(b)

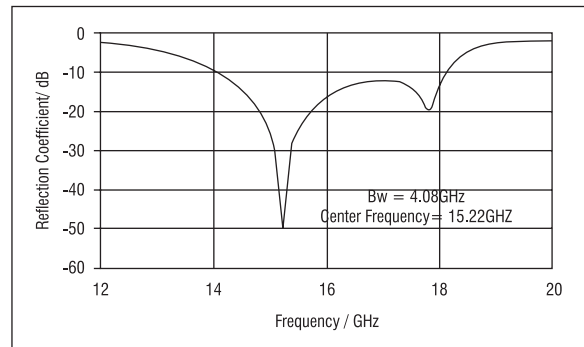

Fig 8: Return loss of optimized antenna

The following parameters have been changed to further enhance the bandwidth from 3.87 GHz to 4.08 GHz.

- The gap G1 between the parasitic patch P1 and the driven patch P2 is increased from 1.3 mm to 1.9 mm and
- The width of the left and right parasitic patch is

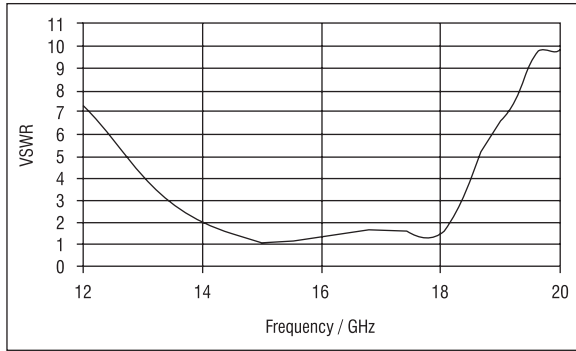

Fig 9: VSWR of the antenna

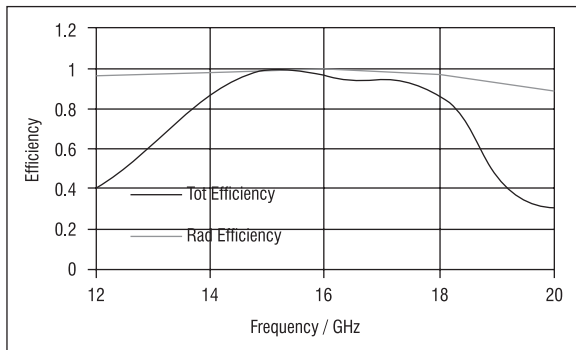

Fig 10: Efficiency

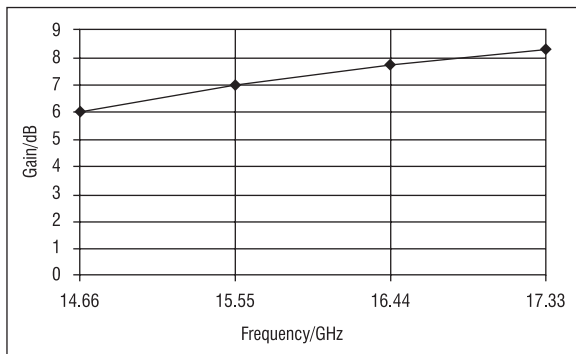

Fig 11: Gain of the antenna

decreased from 3mm to 2.9 mm.

The bandwidth of the proposed antenna has been enhanced to 4.08GHz due to the above mentioned changes in the two parameters. The plot of the reflection coefficient is shown in Fig. 8. The plot of the VSWR with respect to the frequency is illustrated in Fig. 9 and the plot of the efficiency is given in Fig. 10.

VSWR has almost touched 1 at the center frequency. The antenna has gained a maximum total efficiency of 98.65% at 15.55GHz as shown in Fig. 10. The antenna

has a maximum gain of 8.25dBi at 17.33GHz as shown in the plot of the gain in Fig. 11.

CONCLUSION

In this paper wideband Ku-Band antenna has been proposed. The operating bandwidth of the antenna has been enhanced from 1.56GHz to 4.08GHz. The bandwidth of the proposed antenna is from 14.06GHz to 18.14GHz. The VSWR is in the desirable range from 1 to 2. The efficiency of the antenna is also more than 90%. This single band antenna has achieved a maximum gain of 8.25dBi. As the spectrum used for satellite applications in Ku band is from 12GHz through 18GHz, so the proposed antenna can be a good candidate for satellite communication in Ku-Band. The overall size of the antenna proposed here is $15 \times 8 \times 1.64 \text{mm}^3$.

REFERENCES

1. Bryon, E. V., (1970), "A new flush mounted antenna element for phased array application," *Proc. Phased Array Antenna Symp.*
2. Howell, J. Q., (1975), "Microstrip antennas," *IEEE Transactions on Antennas and Propagation, AP-23.*
3. Weinschel, H. D., (1973), "Progress report on development of microstrip cylindrical arrays for sounding rockets," *Phys. and Sci. Lab., New Mexico State University, Las Cruces.*
4. Sanford, G. G., (1974), "Conformal microstrip phased array for aircraft tests with ATS-6," *Proc. Nat. Electronic Conf., 29.*
5. James, J. R., and Wilson, G. J., (1975), "New design technique for microstrip antenna arrays," *Proceedings of 5th European Microwave Conference, pp. 102-106.*
6. Garvin, G. W., Munson, R. E., Ostwald, L. T., and Schroeder, K. G., (1975), "Low profile electrically small missile based mounted microstrip antennas," *Dig. Int. Symp. Antennas Propag. Soc., pp. 244-247.*
7. Balanis. C. A., (2005), "Antenna Theory Analysis and Design". New York: Wiley, 3rd Edition.

8. jana, S., Sinhamahapatra, B., Dey, S., Das, A., Datta, B., Mukherjee, M., Chowdhury, S.K., and Chatterjee, S., (2013), "Single layer monopole hexagonal microstrip patch antenna for satellite television", *International Journal of Soft Computing and Engineering (IJSCE)*, ISSN, pp.2231-2307.
9. Sinhamahapatra, B., Jana, S., Dey, S., Das, A., Datta, B., Mukherjee, M. and Chatterjee, S., (2013), "Dual-Band Size Deducted Un-Equal Arm Y-Shaped Printed Antenna for Satellite Communication", *International Journal of Engineering Research and Development (IJERD)*, e-ISSN, pp.36-40.
10. Saluja, R., Krishna, A. L., Khanna, P. K., Sharma, D., Sharma, P., and Pandey, H. C., (2008), "Analysis of bluetooth patch antenna with different feeding techniques using simulation and optimization." In *Recent Advances in Microwave Theory and Applications. MICROWAVE 2008. International Conference on*, pp. 742-744. IEEE, 2008.
11. Azim, R., Islam, M. T., & Misran, N., (2011), "Dual polarized microstrip patch antenna for Ku-band application", *Informacije MIDEM*, 41(2), 114-117.
12. Dubey, S.K., Pathak, S.K. and Modh, K.K., (2011), "December. High gain multiple resonance Ku-band microstrip patch antenna", In *Applied Electromagnetics Conference (AEMC)*, IEEE (pp. 1-3). IEEE.
13. Misran, N., Islam, M.T., Yusob, N.M., and Mobashsher, A.T., (2009), "August. Design of a compact dual band microstrip antenna for ku-band application", *In Electrical Engineering and Informatics. ICEEI'09. International Conference on* (Vol. 2, pp. 699-702).
14. Samsuzzaman, M., Islam, M.T., Yatim, B., and Ali, M.M.,(2013), *Dual frequency triangular slotted microstrip patch antenna for Ku band applications*", *PrzełqdElektrotechniczny*, 89(1), pp.275-279.
15. Islam, M. T., Misran, N., and Mobashsher, A. T., (2010), "Compact dual band microstrip antenna for Ku-band application," *Information Technology Journal*, vol. 9, no. 2, pp. 354–358.
16. Malisuwan, S., Sivaraks, J., Madan, N., and Suriyakrai, N., (2014), "Design of Microstrip Patch Antenna for Ku-Band Satellite Communication Applications", *International Journal of Computer and Communication Engineering*, 3(6), p.413.
17. Chodavadiya, V.V., and Aggarwal, S.S., (2014), "April. Microstrip Patch Antenna Design for Ku Band Application, In *International Journal of Engineering Research and Technology*, Vol. 3, No. 4.
18. Nor, N. M., Jamaluddin, M. H., Kamarudin, M. R., and Khalily, M., (2016), "Rectangular Dielectric Resonator Antenna Array for 28GHz Applications", *Progress In Electromagnetics Research C*, Vol. 63, 53-61.
19. Bashar B., Qas Elias, "A Wideband Microstrip Patch Antenna for KU-Band Applications", *American Scientific Research Journal for Engineering, Technology, and Sciences (ASRJETS)*, ISSN (Print) 2313-4410, ISSN (Online) 2313-4402.